

HEADWORKS
BIOLOGY
SEPARATION
MEMBRANE
▶ **DISINFECTION**
BIOSOLIDS
SYSTEMS

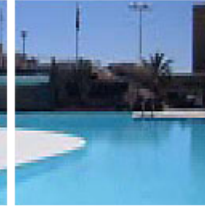
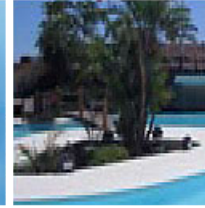

UV

OZONE

SPA

SWIMMING POOL

▶ Ancillary Products

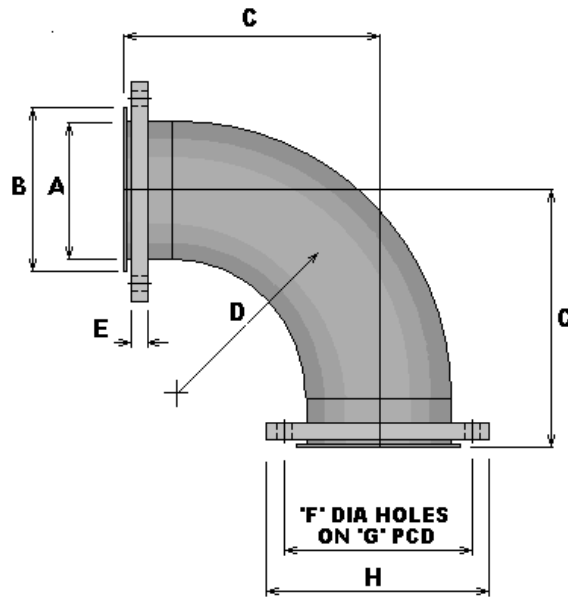

BEND AND TAFT END - 316 SS INTERNAL WELDS DRESSED SMOOTH
BACKING RINGS - ZINC PLATED MILD STEEL

BEND MODEL REF	BS4504 NP10 DIMENSIONS (mm)								IN-OUT (inches)	WEIGHT (kg)
	A	B	C	D	E	F	G	H		
BS BEND3	80	125	204	180	12	18	160	200	3	9
BS BEND6	150	212	278	250	12	22	240	285	6	18
BS BEND8	200	268	330	300	12	22	295	340	8	26
BS BEND10	250	320	374	350	15	22	350	395	10	35
BS BEND12	300	370	424	400	19	22	400	445	12	50
BS BEND14	350	430	474	450	22	22	460	505	14	77

BEND MODEL REF	ANSI 150 DIMENSIONS (mm)								IN-OUT) (inches)	WEIGHT (kg)
	A	B	C	D	E	F	G	H		
AN BEND3	80	125	204	180	12	19	152	191	3	9
AN BEND6	150	212	278	250	12	22	241	279	6	18
AN BEND8	200	268	330	300	12	22	298	343	8	26
AN BEND10	250	320	374	350	15	25	362	406	10	35
AN BEND12	300	370	424	400	19	25	432	483	12	50
AN BEND14	350	430	474	450	22	29	476	533	14	77